

Patent Prosecution Highway Pilot Programme between the Intellectual Property Office of Singapore and the China National Intellectual Property Administration

1. Background

To obtain patent protection for an invention in several countries usually requires the invention to be searched and examined in each of the countries. If the patent authorities in these countries were to share the results of their search and/or examination with each other, the opportunity for a patent office to make reference to earlier work done could have several potential benefits:

- Reduced work – Reference to the earlier work done could reduce or even eliminate the need for subsequent search and examination work.
- Faster prosecution – The reduced work could generally lead to a faster prosecution of the patent application.
- Better search and examination – The other patent authorities might have access to databases unavailable (e.g. specific technical databases, local databases, databases in other languages) to the examiner, therefore the opportunity to refer to these search and examination results could provide the examiner with information on and assessment of prior art that he or she would otherwise not have access to.

2. Patent Prosecution Highway Pilot Programme

2.1 The Patent Prosecution Highway (PPH) pilot programme between the Intellectual Property Office of Singapore (IPOS) and the China National Intellectual Property Administration (CNIPA) is one way for the two offices to share their search and examination results with each other.

2.2 PPH Mottainai

(1) Where IPOS is the Office of Earlier Examination (OEE) and the IPOS application contains claims that are determined to be allowable/patentable, the applicant may request accelerated examination at the CNIPA for the corresponding application or national phase application filed with the CNIPA as the Office of Later Examination (OLE).

(2) For PPH Mottainai using national products from the CNIPA as OEE, the earliest application must be filed with the CNIPA or IPOS.

(3) Where the CNIPA is the OEE and the CNIPA application contains claims that are determined to be allowable/patentable, the applicant may request accelerated examination of the corresponding application or national phase application filed with IPOS as the OLE by furnishing certain information of the CNIPA application as set out in the requirements and procedures below. For the avoidance of doubt, the applicant is required to provide all necessary documents to IPOS.

2.3 The IPOS application, which validly claims priority to multiple CNIPA or direct PCT applications, or which is the divisional application validly based on the originally filed application that is included in section (2.2) above, is also eligible.

- 2.4 The requirements and procedures for filing a request with the CNIPA for participation in the PPH pilot programme are available from the CNIPA website at: <https://www.cnipa.gov.cn/col/col341/index.html>

3. PPH Pilot programme

- 3.1 The PPH pilot programme commenced on September 1, 2013 and will be extended till August 31, 2026.
- 3.2 IPOS and the CNIPA will evaluate the results of the pilot programme to determine whether and how the programme should be fully implemented. The Offices may also suspend or terminate the PPH pilot programme if the volume of participation exceeds manageable level, or for any other reason, by providing three (3) months in writing to the other Office. Notice will be published if the PPH pilot programme will be suspended or terminated for any reason.

4. Requirements and procedures for requesting accelerated examination of an IPOS patent application under the PPH

4.1 Requirement

- (1) The IPOS application has not had a valid Patents Form 10 (Request for Search Report or Supplementary Search Report), Patents Form 11 (Request for Search and Examination Report) or Patents Form 12 (Request for Examination Report) filed yet.
- (2) At least one corresponding application exists in the CNIPA and has one or more claims that are determined to be allowable/patentable¹ in a substantive examination carried out by the CNIPA.
- (3) All claims in the IPOS application must sufficiently correspond to the allowable/patentable claims in the CNIPA application. Claims will be considered to sufficiently correspond where, accounting for differences due to translations and claim format requirements, the claims are of the same or similar scope, or the claims are narrower in scope. In this regard, a claim that is narrower in scope occurs when a claim in the IPOS application is amended to be further limited by an additional technical feature that is supported in the specification.
- (4) Examination has not begun on the IPOS application.
- (5) Diagrams depicting a list of scenarios in which a request for accelerated examination of the IPOS application under the PPH pilot programme can be made are found in Annex I.

4.2 The Procedures

- (1) File duly completed Patents Form 11 (Request for Search and Examination Report) or Patents Form 12 (Request for Examination Report). These forms can be found at <https://www.digitalhub.ipos.gov.sg/> (electronic versions for online filing).
- (2) The Patents Form 11 or Patents Form 12 must be accompanied by:

¹ Allowed claims from a utility model cannot be used to form the basis for requesting PPH in IPOS.

- (a) a copy of all office actions of the CNIPA application being relied upon;
 - (b) a copy of the allowable/patentable patent claims referred to in (2)(a) above;
and
 - (c) a claims correspondence table showing the relatedness of the allowable/patentable claims referred to in (2)(a) above to the claims in the current IPOS application. The format of the Claims Correspondence Table is found in Annex II.
- (3) The documents listed in (2)(a) above can be either the:
- a) national work product including Decision to Grant a Patent, First/Second/Third/...Office Action, Decision of Refusal, Reexamination Decision or Invalidation Decision established by the CNIPA as the national Office during the processing of a national application or a Patent Cooperation Treaty (PCT) application that has entered the national phase before the CNIPA; or
 - b) PCT work product including (i) written opinion established by the CNIPA as the International Searching Authority or International Preliminary Examining Authority or (ii) the international preliminary examination report issued within the framework of the PCT.
- (4) For avoidance of doubt, a copy of the patent grant without the documents listed in (2)(a), (b) and (c) above will not qualify for the PPH.
- (5) The checkbox for “ASPEC/PPH” must be selected in the Patents Form 11 or Patents Form 12.
- (6) All subsequent correspondences with IPOS must be similarly marked with the phrase “IPOS-CNIPA PPH acceleration requested”.

4.3 **Cited Documents**

A copy of each of the documents cited in the documents submitted under paragraph 4.2 (2)(a) is not required at the time of filing the PPH request. IPOS may, however, require the applicant to furnish a copy of any document cited subsequently.

4.4 **Translations**

- (1) The documents in paragraph 4.2 must be accompanied by an English translation if they are not originally in English, at the time of filing the PPH request.
- (2) The documents in paragraph 4.3 may be filed in their original language. However, IPOS may subsequently request for an English translation of a document or a part of a document if an English abstract of the cited document is not available.
- (3) If it is not possible for IPOS to understand the English translation of any document, IPOS can request the applicant to resubmit the English translation of that document.

- 4.5 IPOS applications which request accelerated prosecution under the PPH pilot programme will be processed in accordance with the Singapore Patents Act (Cap. 221) and the Singapore Patents Rules. The legislations can be found at: <http://www.ipos.gov.sg/AboutIP/IPLegislation.aspx>
- 4.6 In those instances where the PPH request does not meet all the requirements and procedures set forth above, the applicant will be notified and the deficiencies in the request will be identified. The applicant will be given one opportunity to correct formal deficiencies identified in the request. If the request is not corrected, the application will be taken out of the PPH pilot programme and the applicant will be notified.
- 4.7 Applicants should seek professional advice on patent matters in Singapore, in particular, with reference to section 30 (Grant of patent) and section 69 (Restrictions on relief for infringement) of the Singapore Patents Act (Cap. 221).

5. Enquiries

For enquiries relating to the Patent Prosecution Highway pilot programme, please send an email to pph@ipos.gov.sg .

INTELLECTUAL PROPERTY OFFICE OF SINGAPORE

DATE: 2 June 2022

Annex I

Scenarios using the National Work Product

Scenario 1(a): The IPOS application validly claims priority under section 17 of the Singapore Patents Act (Cap. 221) from the CNIPA application being relied upon for the PPH request.

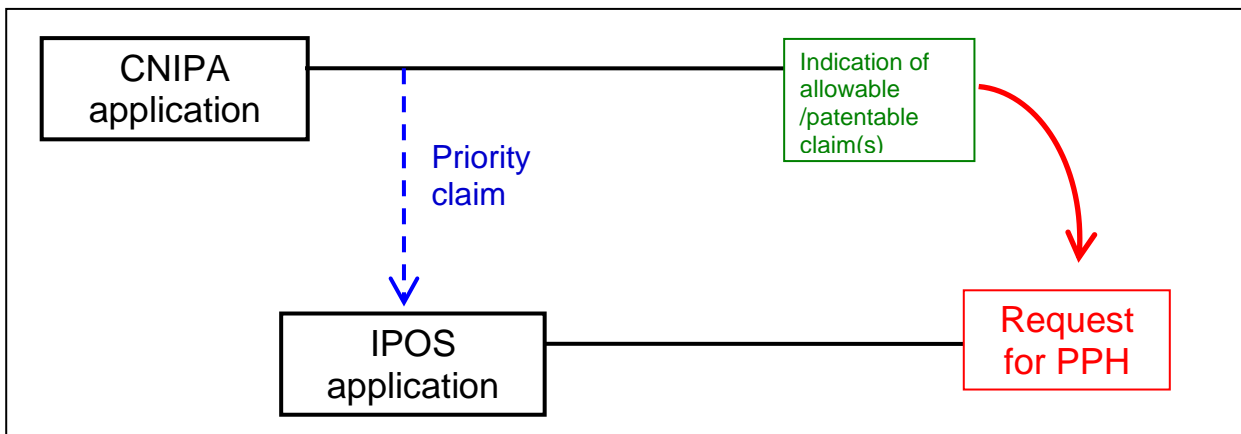

Scenario 1(b): The request for PPH can also be made where the CNIPA application claims priority from the IPOS application and the CNIPA application is being relied upon for PPH request.

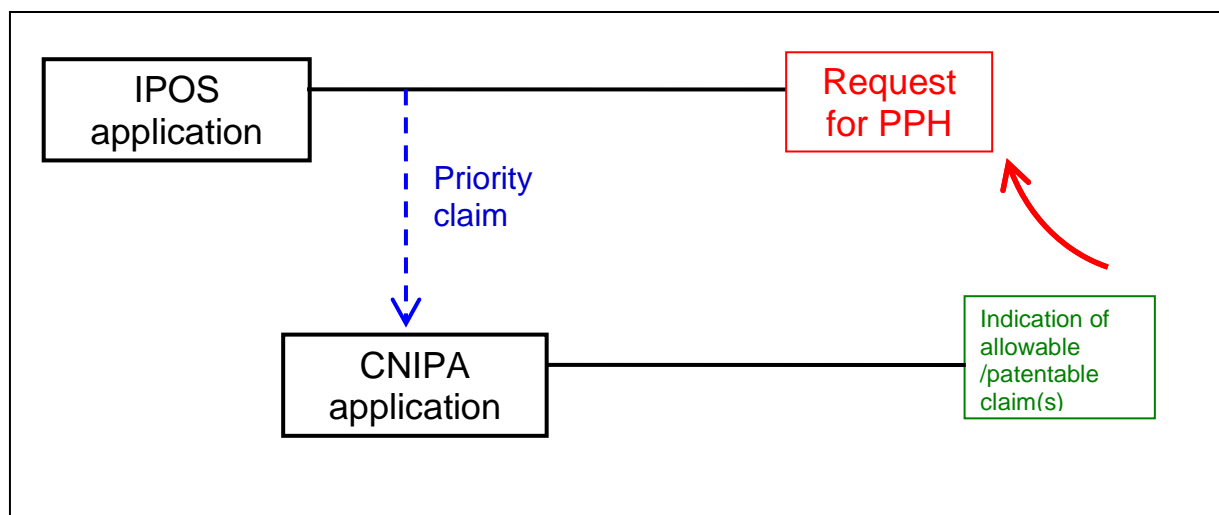

Scenario 2(a): The IPOS application validly claims priority under section 17 of the Singapore Patents Act (Cap. 221) from the CNIPA application being relied upon for the PPH request and applications filed in any office other than the IPOS or the CNIPA.

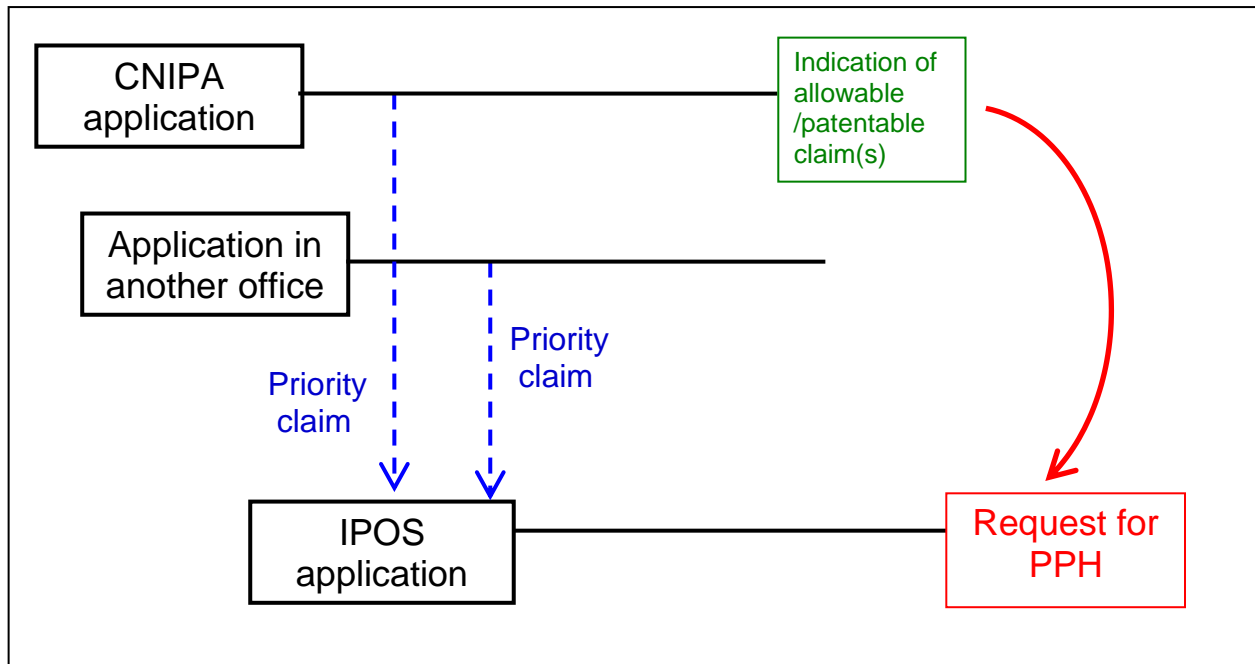

Scenario 2(b): The CNIPA application being relied upon for the PPH request validly claims priority from the IPOS application and applications filed in any office other than the IPOS or the CNIPA.

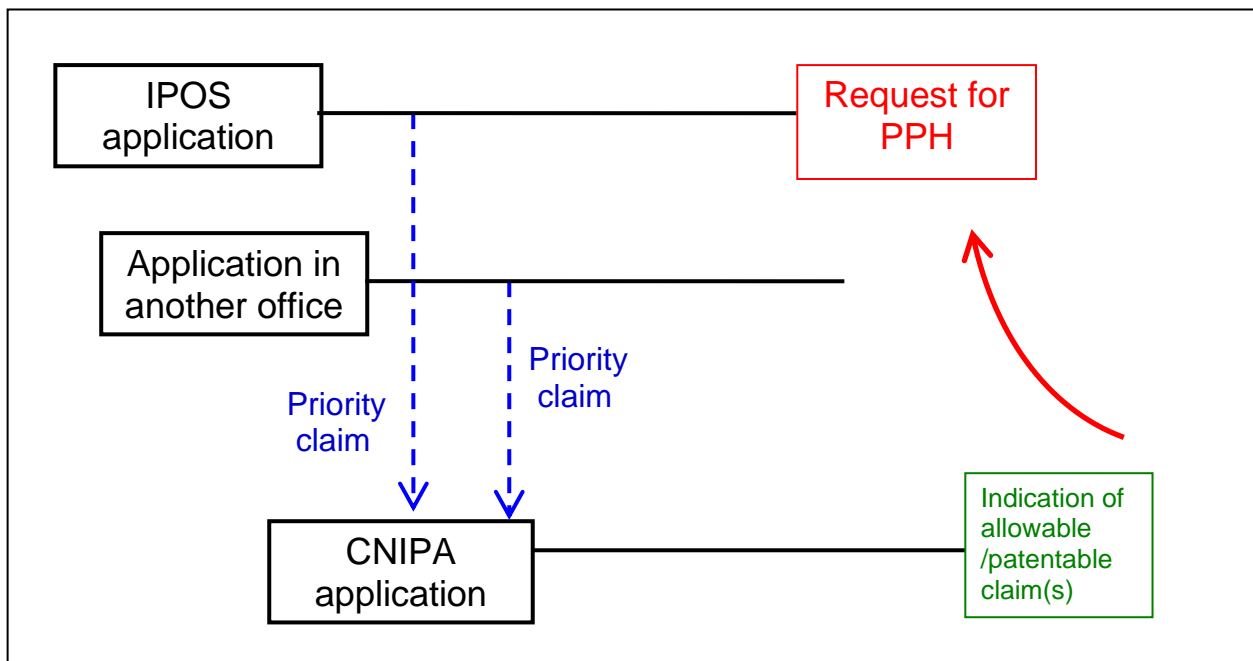

Scenario 3(a): The IPOS application is a divisional application of the IPOS application referred to in (1) above, and said divisional application validly claims priority under section 17 of the Singapore Patents Act (Cap. 221) from the CNIPA application being relied upon for the PPH request.

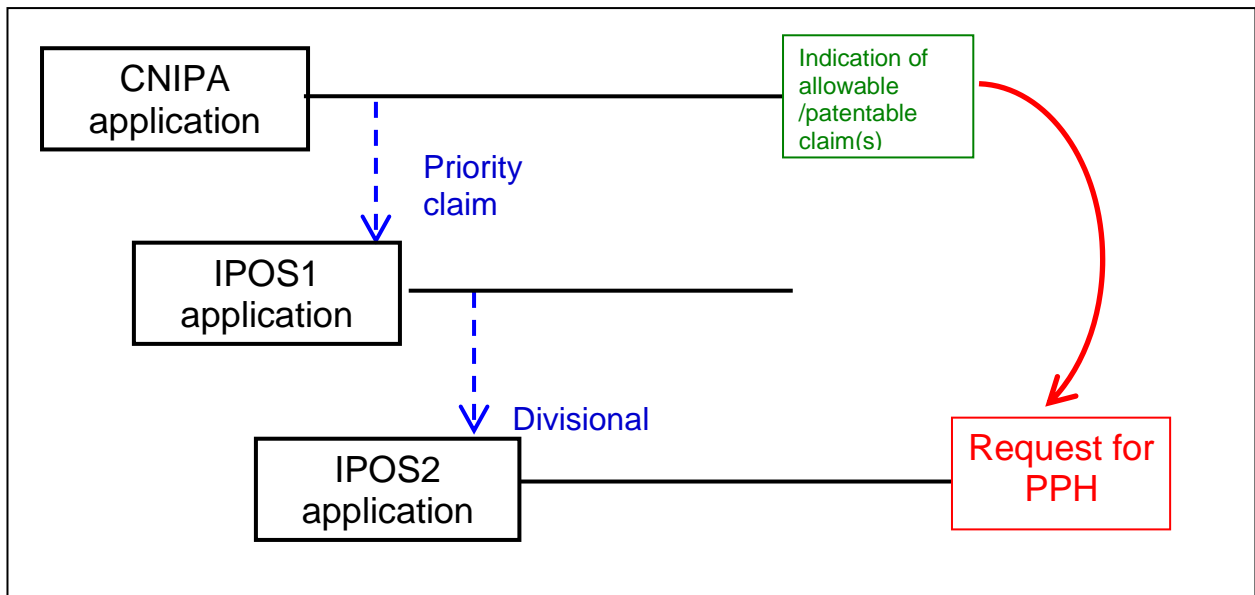

Scenario 3(b): The CNIPA application is a divisional application of the CNIPA application referred to in (1) above, and said divisional application validly claims priority from the IPOS application and the divisional application from CNIPA could be relied upon for the PPH request.

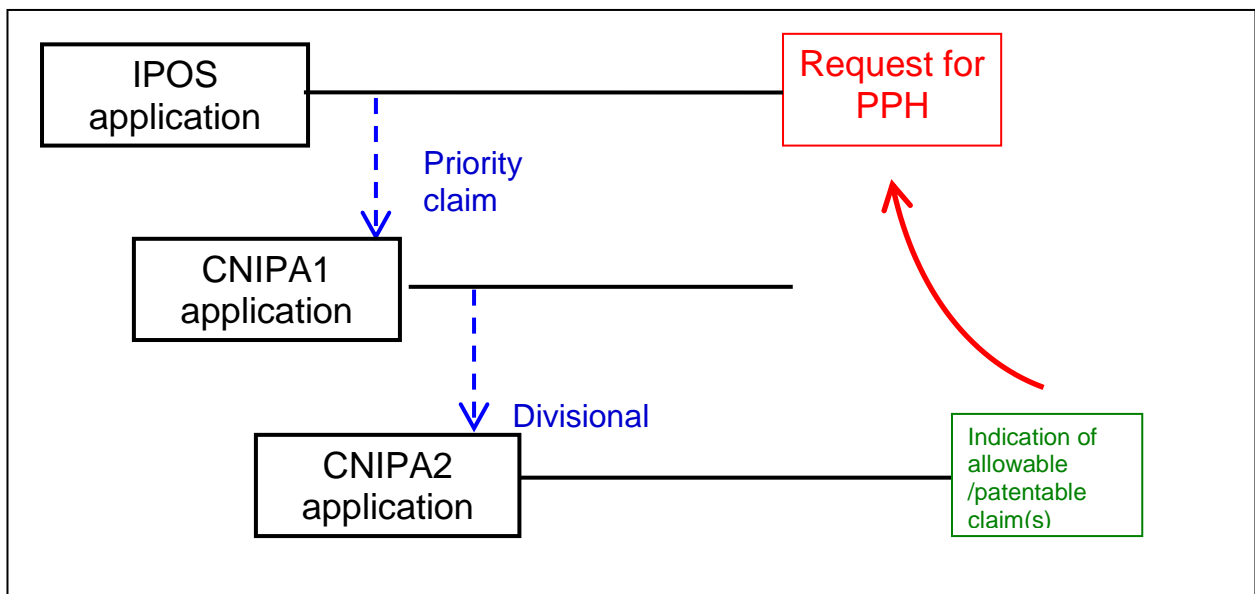

Scenario 4: The IPOS application validly claims priority under section 17 of the Singapore Patents Act (Cap. 221) from a CNIPA application, and the CNIPA application being relied upon for the PPH request also validly claims priority under China law from said earlier CNIPA application.

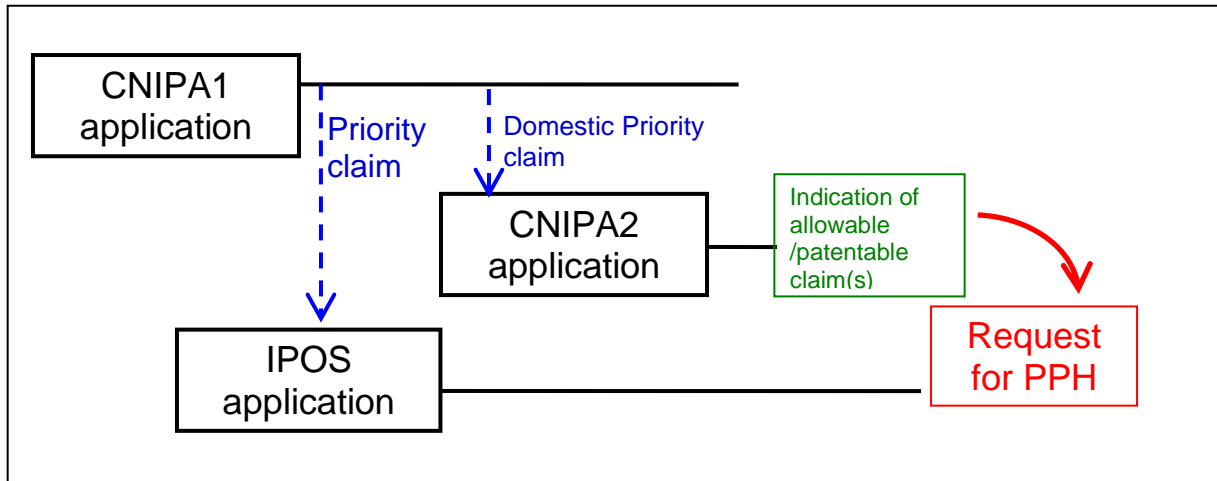

Scenario 5: The IPOS application is a divisional application of the IPOS application referred to in (3) above, and said divisional application validly claims priority under section 17 of the Singapore Patents Act (Cap. 221) from a CNIPA application, and the CNIPA application being relied upon for the PPH request also validly claims priority under China law from said earlier CNIPA application.

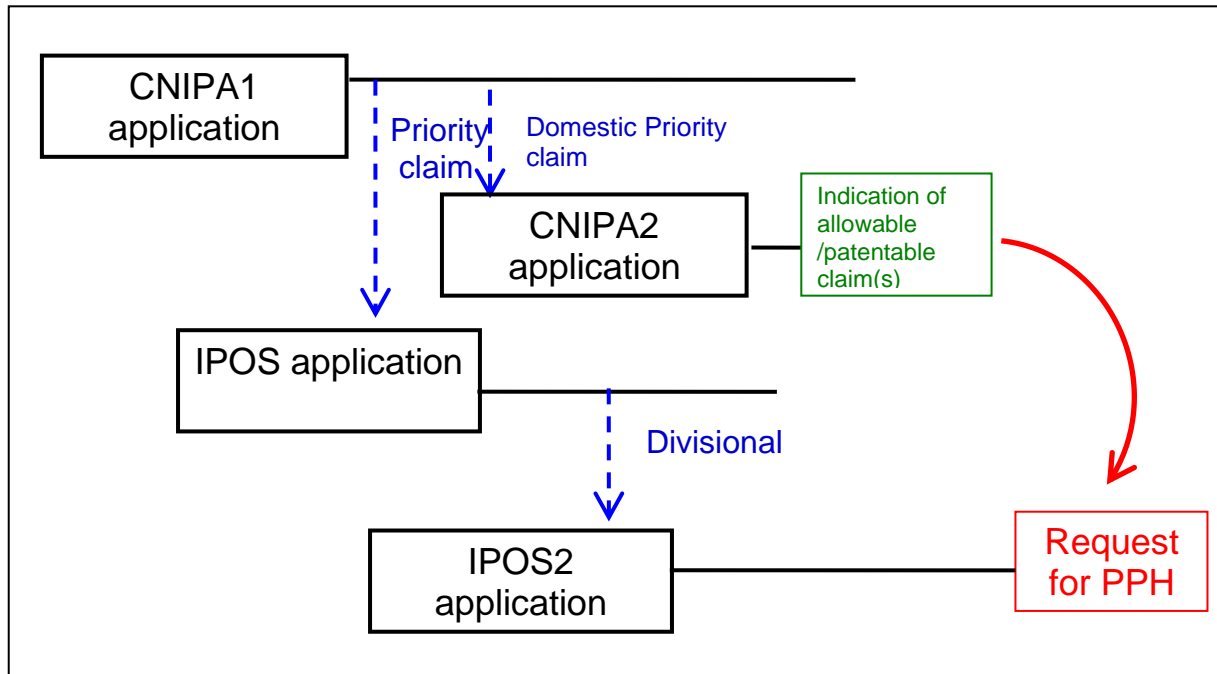

Scenario 6(a): The IPOS application validly claims priority under section 17 of the Singapore Patents Act (Cap. 221) from a PCT application. The CNIPA application being relied upon for the PPH request is a national phase entry of the PCT application.

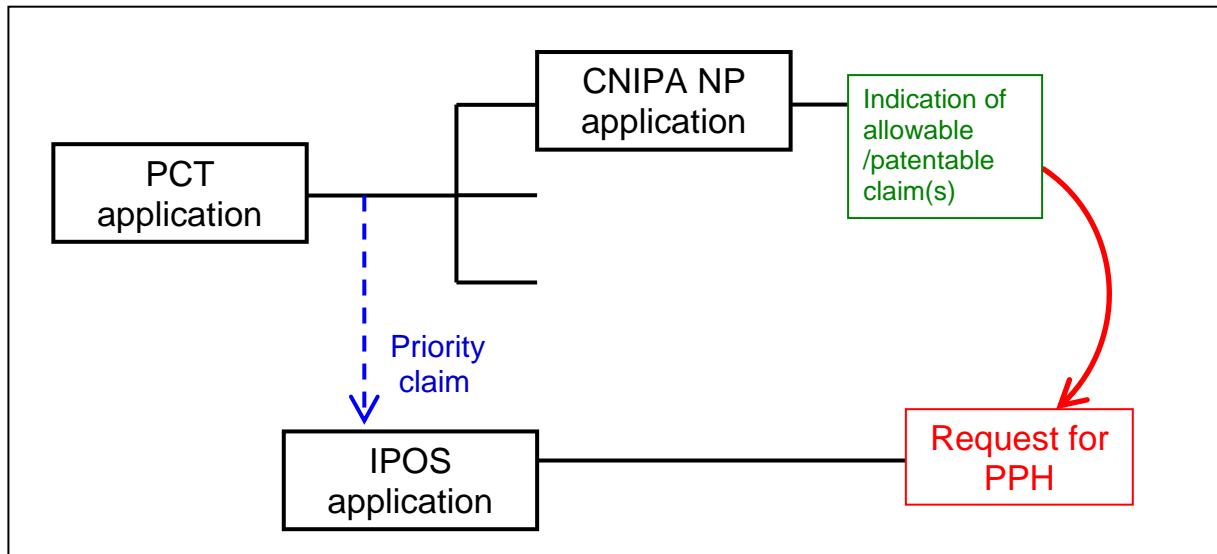

Scenario 6(b): The CNIPA application validly claims priority from a PCT application. The CNIPA application could be relied upon for the PPH request for a IPOS national phase entry of the PCT application.

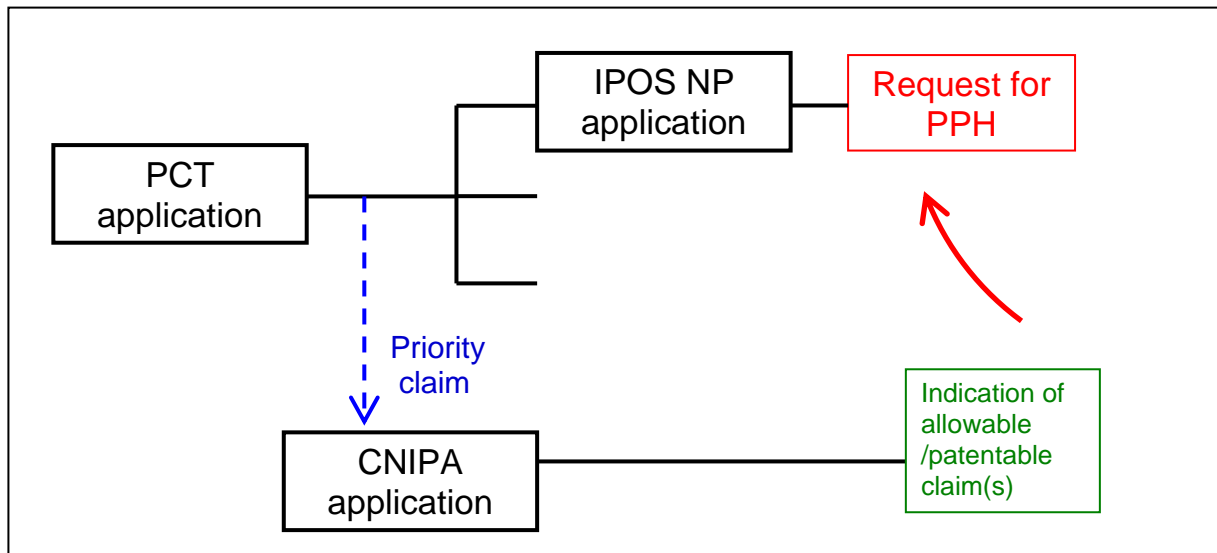

Scenario 7(a): The IPOS application is a national phase entry of a PCT application (“IPOS NP application”), and the IPOS application validly claims priority under section 17 and section 87 of the Singapore Patents Act (Cap. 221) from a CNIPA national application, and it is this CNIPA national application that is being relied on for the PPH request.

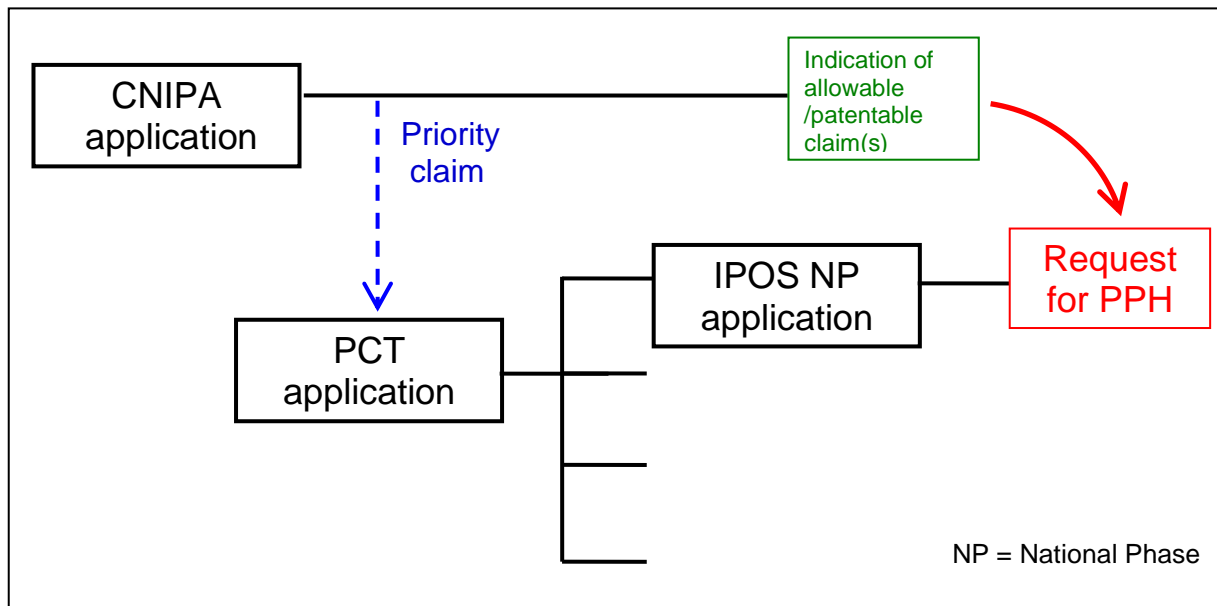

Scenario 7(b): The CNIPA application is a national phase entry of a PCT application (“CNIPA NP application”), and the CNIPA application validly claims priority from a IPOS national application, and it is the CNIPA NP application that is being relied on for the PPH request.

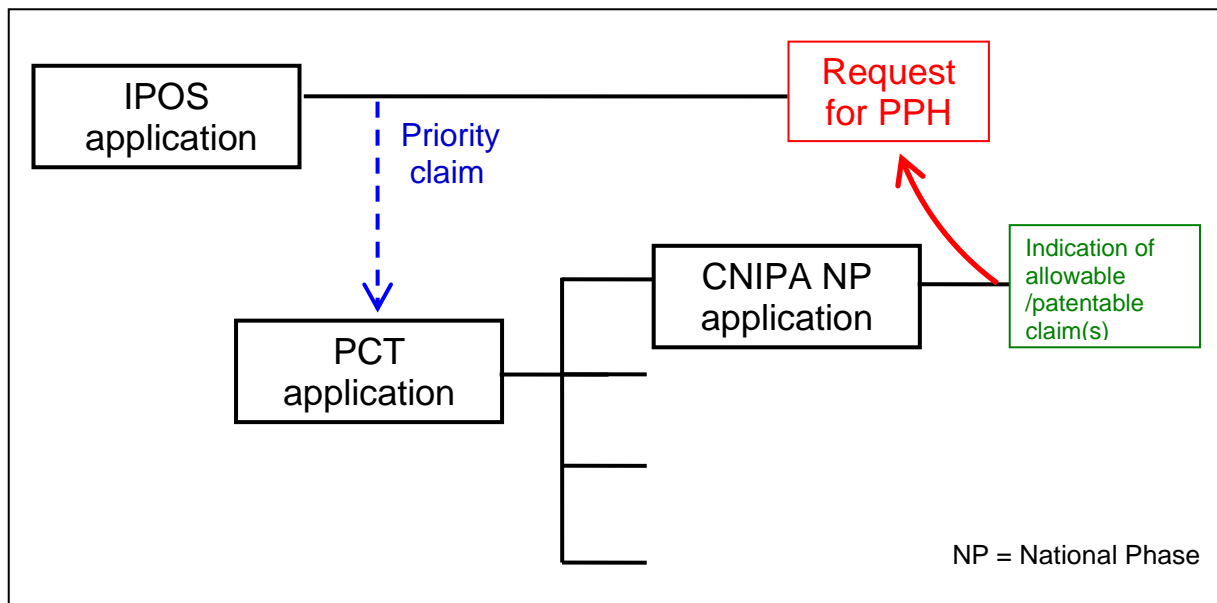

Scenario 8: The IPOS application is a national phase entry of a PCT application, and the IPOS application validly claims priority under section 17 and section 87 of the Singapore Patents Act (Cap. 221) from a PCT application, and it is this PCT application that is being relied on for the PPH request.

Patents Act (Cap. 221) from a CNIPA national application. The CNIPA application being relied upon for the PPH request is a national phase entry of the same PCT application, and the CNIPA application being relied upon for the PPH request validly claims priority under China law from said CNIPA national application.

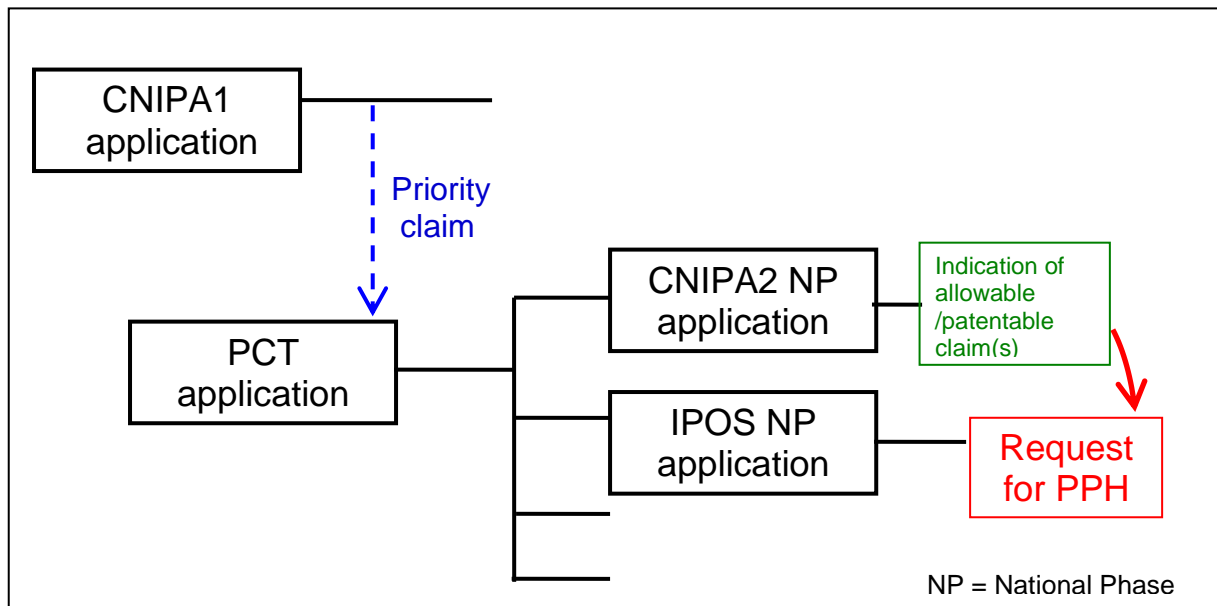

Scenario 9: There is a first PCT application. There is a second PCT application validly claiming priority from the first PCT application. The IPOS application is a national phase entry of the second PCT application, and the IPOS application validly claims priority under section 17 and section 87 of the Singapore Patents Act (Cap. 221) from the first PCT application. The CNIPA application being relied upon for the PPH request is a national phase entry of the second PCT application, and the CNIPA application validly claims priority under China law from the first PCT application.

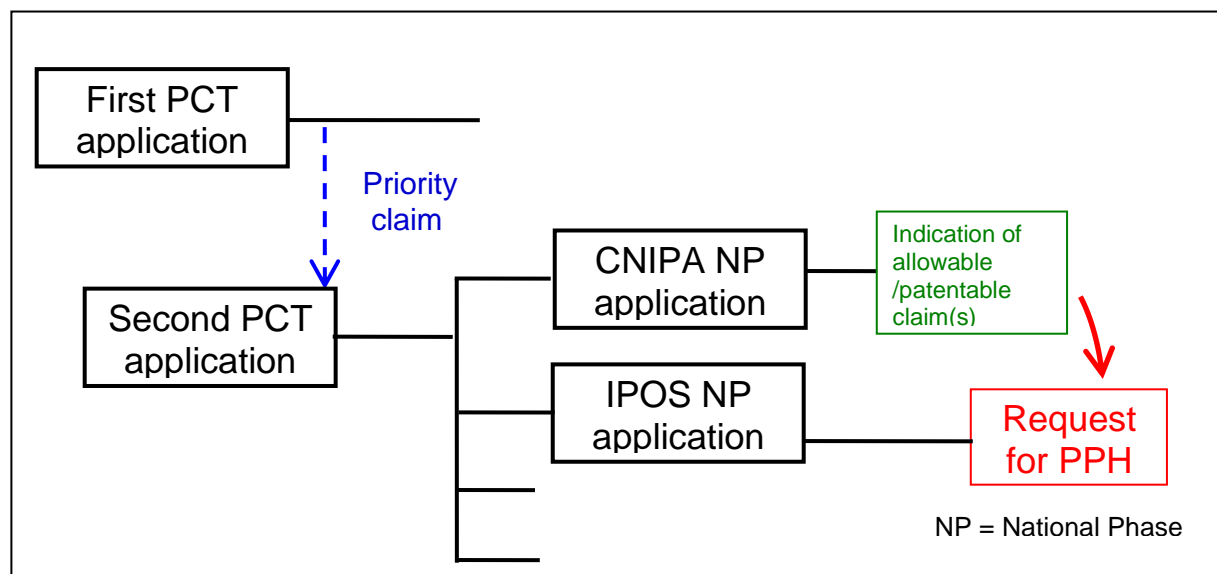

Scenario 10: There is a first PCT application. There is a second PCT application validly claiming priority from the first PCT application. The IPOS application ("IPOS NP application")

is a national phase entry of the second PCT application. The CNIPA application (“CNIPA NP application”) being relied upon for the PPH request is a national phase entry of the first PCT application.

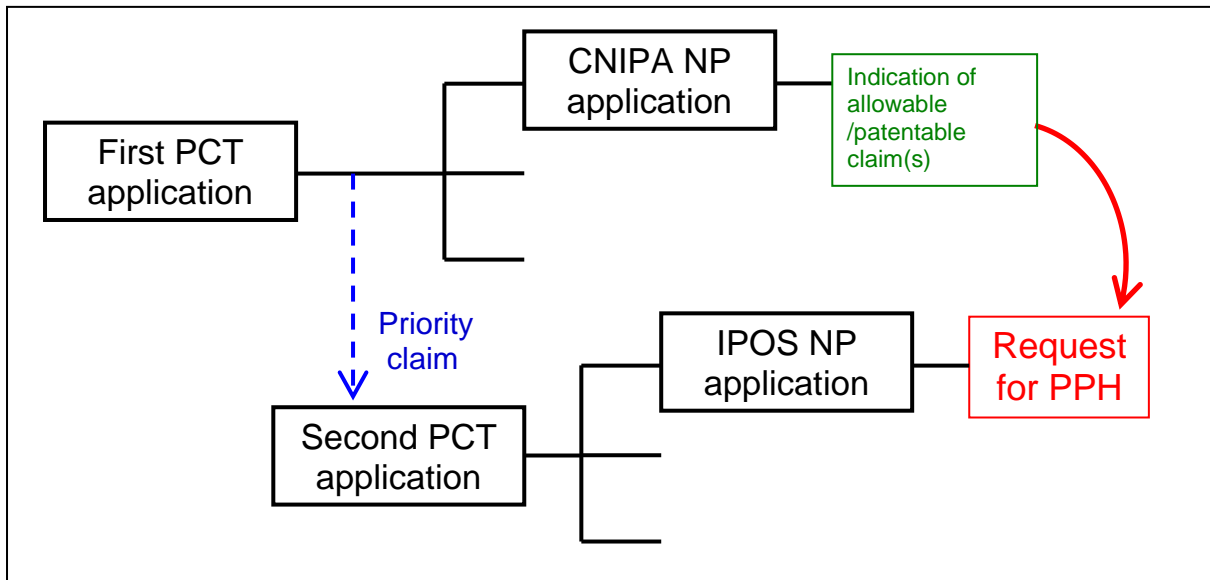

Scenario 11: The IPOS application (“IPOS NP application”) and the CNIPA application (“CNIPA NP application”) being relied upon for the PPH request, are national phase entries of the same PCT application.

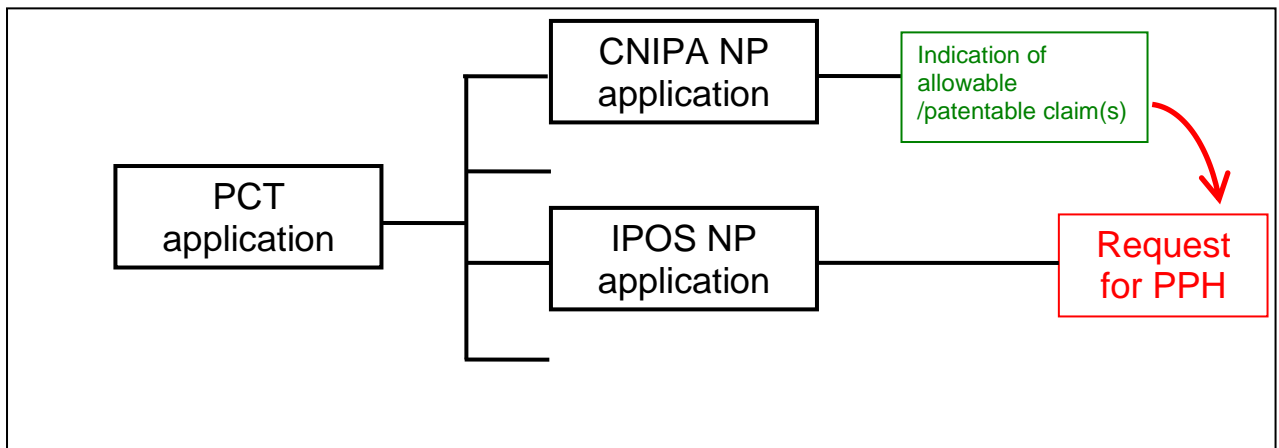

Scenarios using the PCT Work Product

Scenario 12: The IPOS application is a national phase entry of the PCT application (“IPOS NP application”). The PCT application is being relied upon for the PPH request and it is examined by the CNIPA as International Authority (IA).

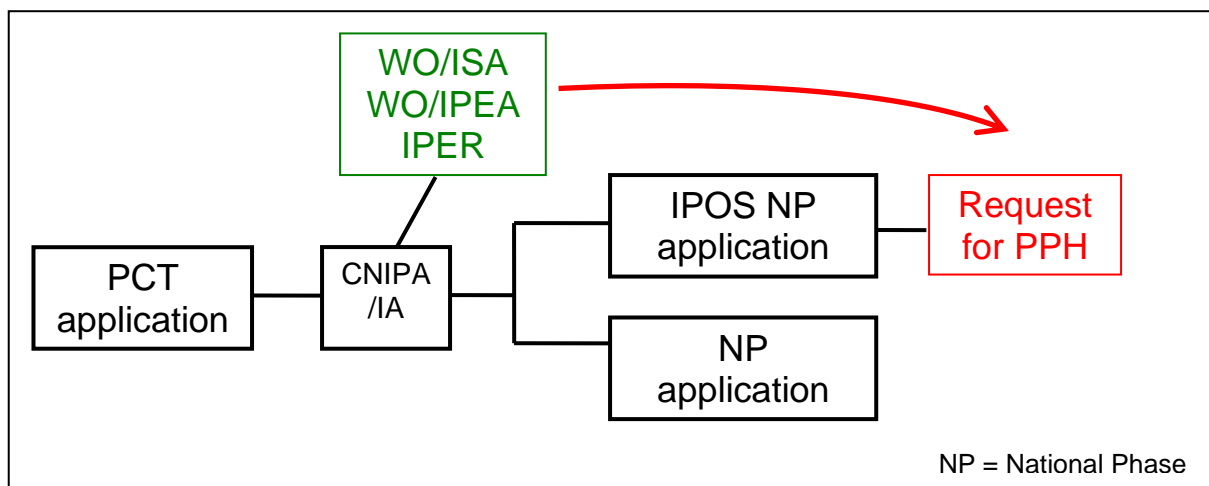

Scenario 13: There are two PCT applications, the second application validly claiming priority from the first application. The IPOS application is a national phase entry of the second PCT application (“IPOS NP application”). The second PCT Application is being relied upon for the PPH request and it is examined by the CNIPA as International Authority (IA).

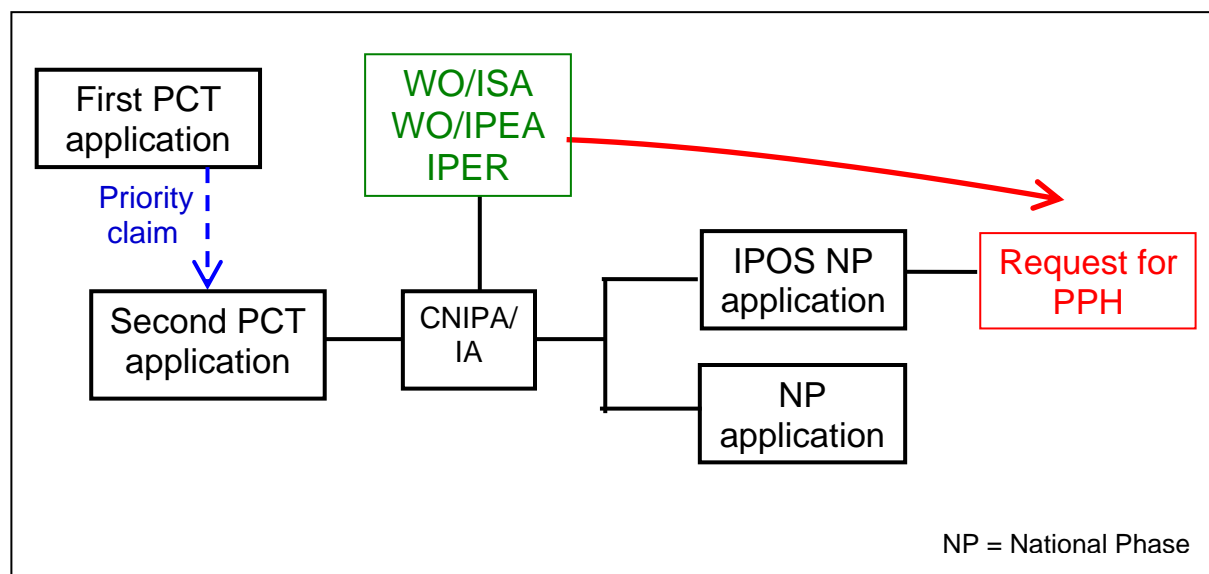

Scenario 14: There is a first application filed in any office. The PCT application validly claims priority from the first application. The IPOS application is a national phase entry of the PCT application (“IPOS NP application”). The PCT application is being relied upon for the PPH request and it is examined by the CNIPA as International Authority (IA).

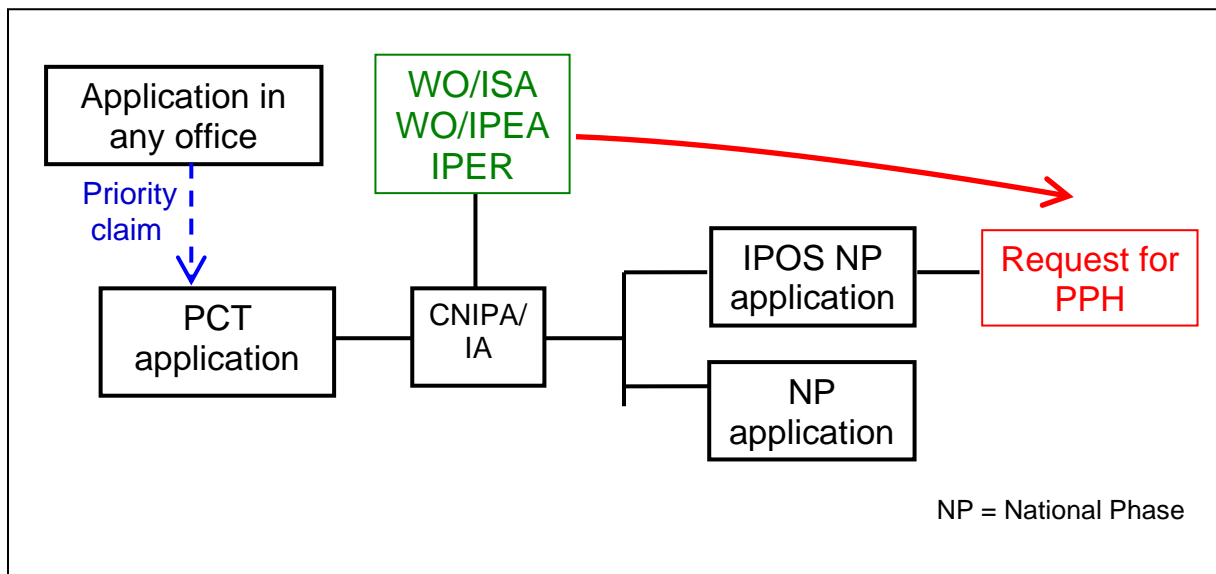

Scenario 15: The PCT application validly claims priority from an IPOS application. The PCT application is being relied upon for the PPH request for the IPOS application and it is examined by the CNIPA as International Authority (IA).

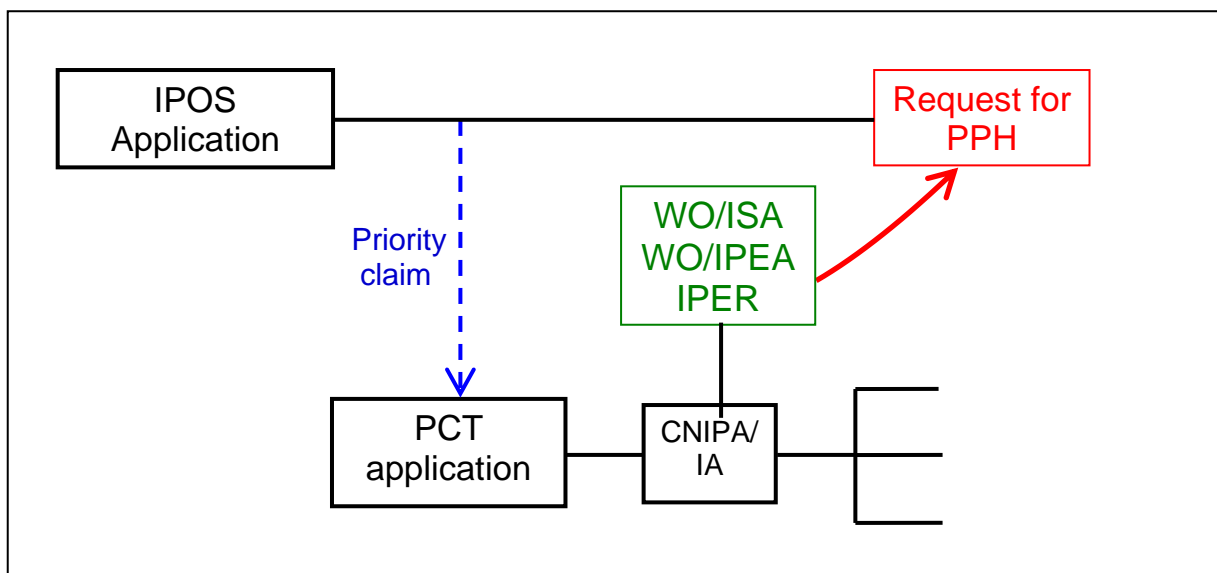

Scenario 16: There are two IPOS application. The PCT application validly claims priority from the first IPOS application (“IPOS 1 Application”). The second IPOS application (“IPOS 2 Application”) is a divisional application of the first IPOS application. The PCT application, examined by the CNIPA as International Authority (IA), is being relied upon for the PPH request for the second IPOS application.

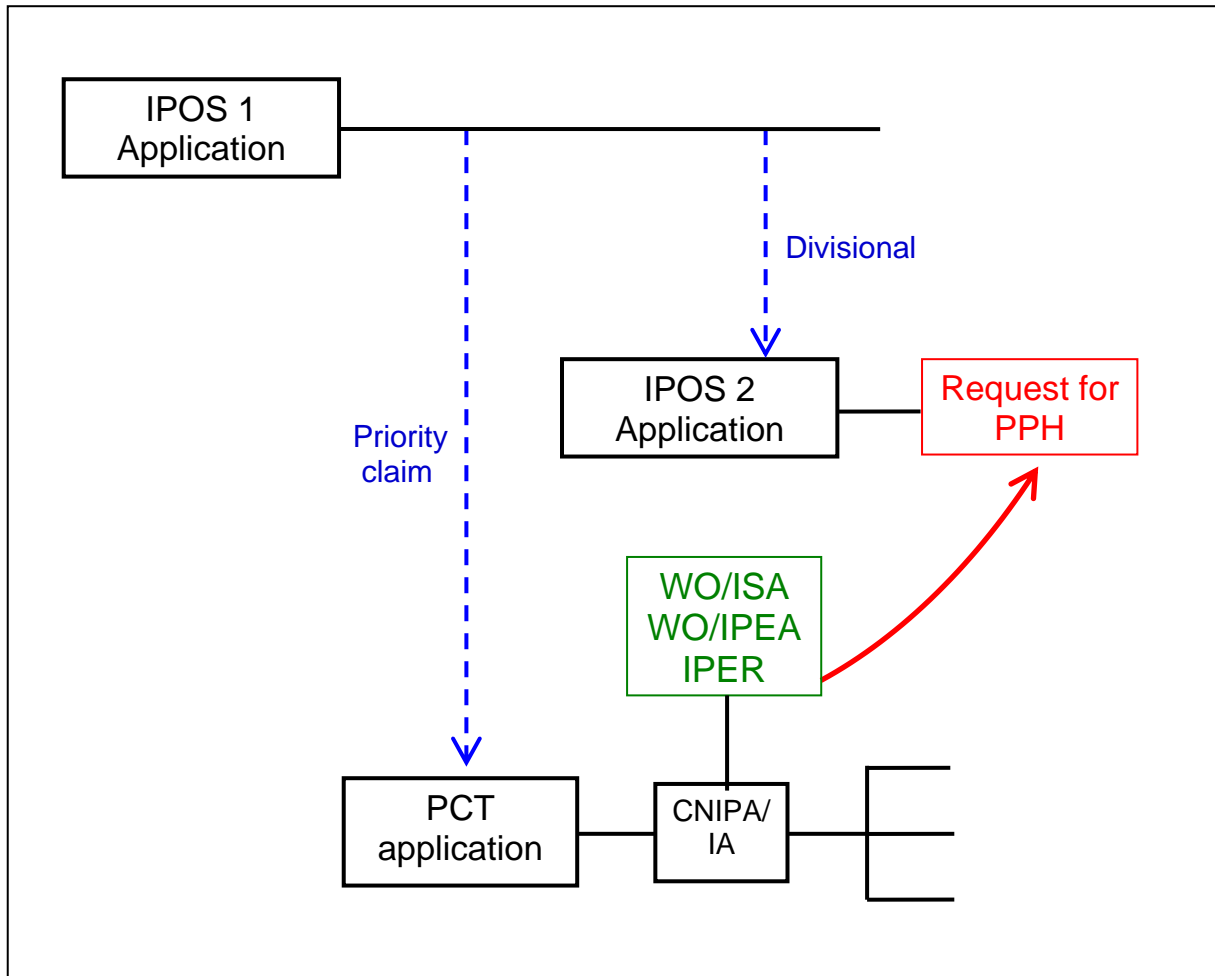

Scenario 17: There are two PCT applications, the second application validly claiming priority from the first application. The IPOS application is a national phase entry of the second PCT application (“IPOS NP application”). The first PCT application is being relied upon for the PPH request and it is examined by the CNIPA as International Authority (IA).

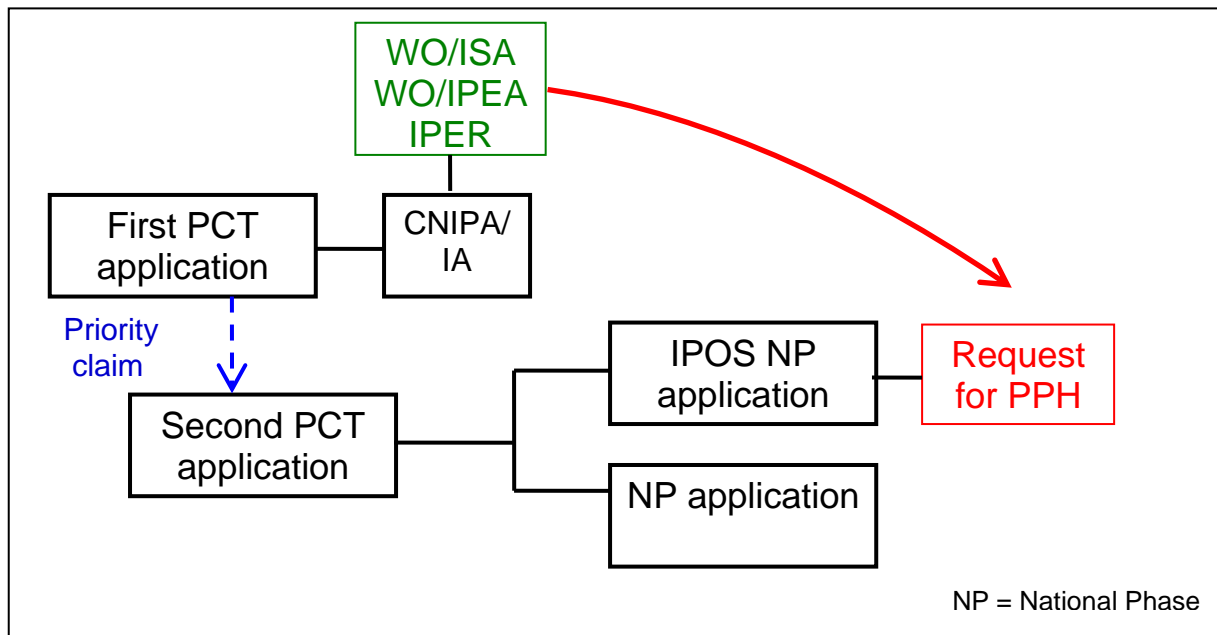

Scenario 18: The IPOS application validly claims priority under section 17 of the Singapore Patents Act (Cap. 221) from the PCT application. The PCT application is being relied upon for the PPH request and it is examined by the CNIPA as International Authority (IA).

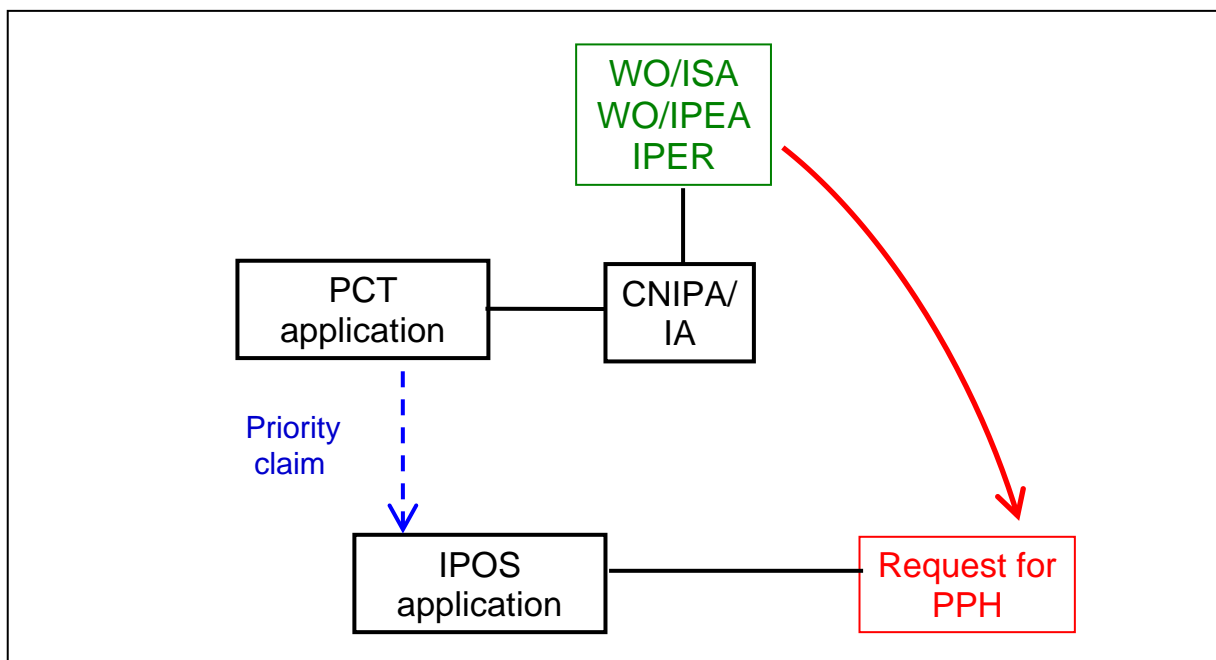

Scenario 19: The IPOS application is a divisional application of another IPOS application that is a national phase entry of a PCT application (“IPOS NP application”). The PCT application is being relied upon for the PPH request and it is examined by the CNIPA as International Authority (IA).

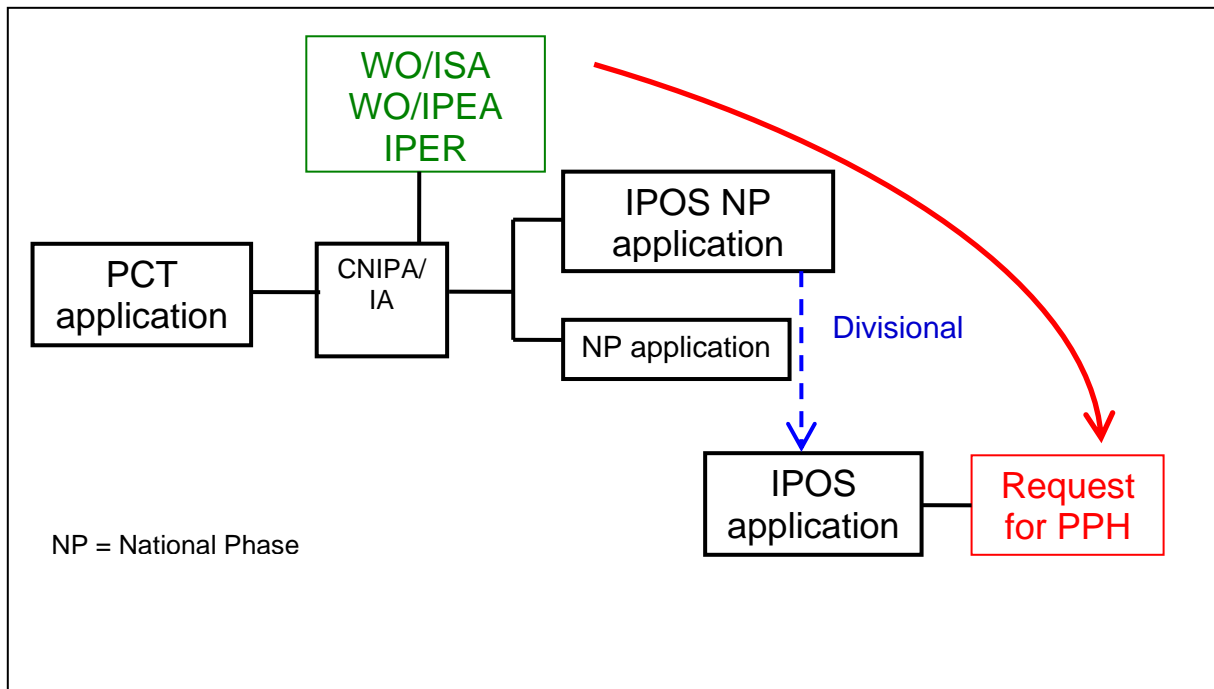

Note: The PCT work products are namely the Written Opinion of the International Search Authority (WO/ISA), the Written Opinion of the International Preliminary Examining Authority (WO/IPEA) or the International Preliminary Examination Report (IPER).

